

Center Drill >>>

The "i-Center" is a trademark of Nine9, the developer of the first indexable center drill in the world. (Patented) Offering an indexable insert system for the 1st time, Nine9's "i-Center" design improves your process performance.

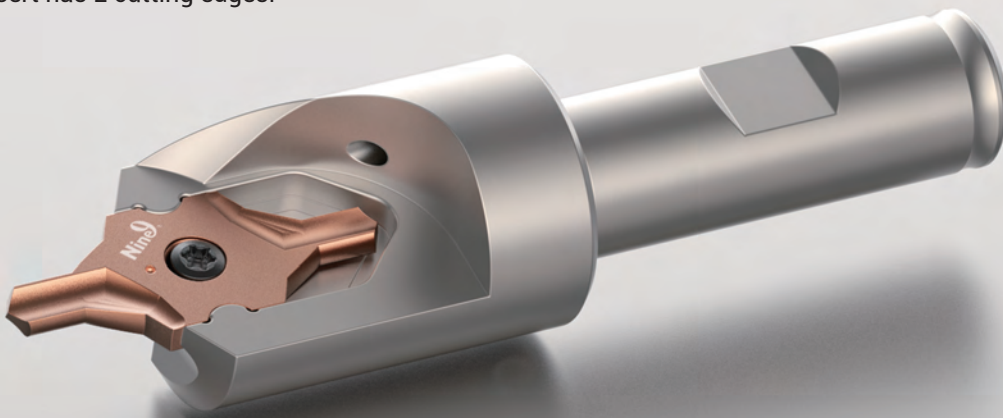

- 2 cutting flutes design same as carbide center drill for high performance speed and feed rate.
- Each insert has 2 cutting edges.



Features >>>

▶ High Speed, High Feed Rate

- The special ground insert and rigid holder design facilitate high performance speed and feed rates. For example, drilling alloy steel at 6000 rpm and feed rate of 600 mm/min. (0.1 mm/rev.)

▶ Excellent Repeatability

- The positioning repeatability of the insert is within 0.02 mm (.0008") in radial direction, thus ensuring conformity to any national standards.

▶ Easy Tool Length Setting

- The axial position accuracy of the insert is 0.05 mm (.002"). It is not necessary to reset the tool length when changing the insert or cutting edge.

▶ Extended Tool Life

- Coolant can be supplied through the center of the holder to increase performance and extend tool life.
- Insert geometry, grades and coating process are specifically engineered for centering applications.

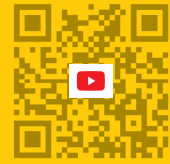

Applications

Excellent repeatability
No need tool length
re-setting while changing
insert or cutting edge.

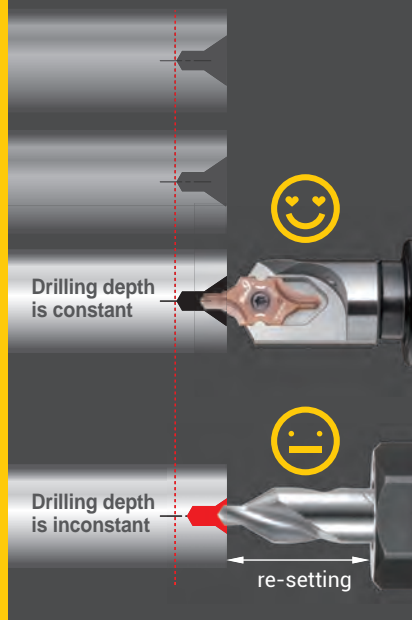

DIN 332 Form R

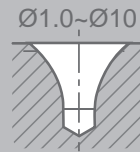

DIN 332 Form A



DIN 332 Form A+B

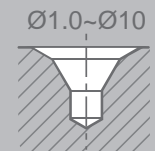

ANSI 60°

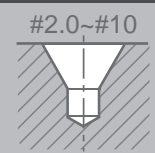

“ World’s first indexable center drill.
Shortens set up and
center drilling time.
Increases tool life and
reduces tooling costs. ”



NC2057



- P35 grade, AlTiN + TiSiN coating, Universal grade for all kind of steel.
- Double-edged cutting, fully ground insert for improving machining stability. (IC10 inserts)

NC5074



- P40 grade, Helica (AlCrN) coating, design for small diameter center drill (IC08 inserts).

NC2033



- K20F grade, TiAlN coated, for carbon steel, alloy steel, high alloy steel and cast iron.

2

i-Center

DIN332 Form R

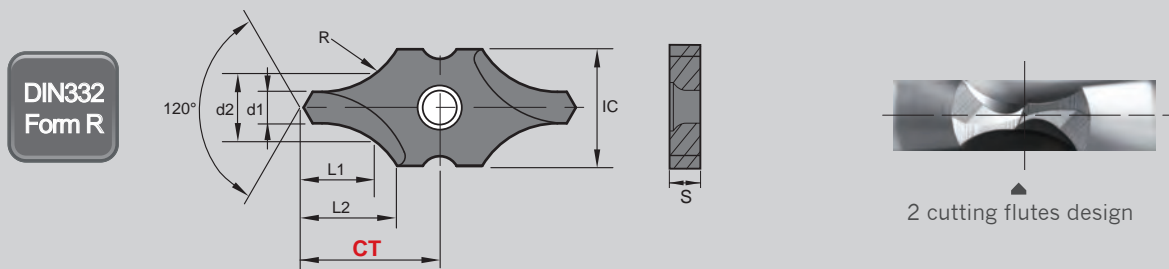

2



► For DIN332
Form R Center Hole >>

i-Center

IC	Code	Parts No.	Coating	Grade	d1	d2	L1	L2	R	S	CT ±0.025	
08	032211	I9MT08T1R0100-NC5074	Helica	P40	1.00	+ 0.14 0	2.12	2.16	4.14	2.8	2.00	7.55
	032212	I9MT08T1R0125-NC5074			1.25		2.65	2.74	4.64	3.5		7.90
	032213	I9MT08T1R0160-NC5074			1.60		3.35	3.45	5.13	4.5		8.40
	032214	I9MT08T1R0200-NC5074			2.00		4.25	4.45	6.08	5.65		9.10
10	031200	I9MT1003R0100-NC2057	AlTiN+ TiSiN	P35	1.00	+ 0.14 0	2.12	2.16	4.72	2.8	3.00	12.35
	031201	I9MT1003R0125-NC2057			1.25		2.65	2.74	5.22	3.5		
	031202	I9MT1003R0150-NC2057			1.50		3.60	3.67	6.14	5.0		
	031203	I9MT1003R0160-NC2057			1.60		3.35	3.45	5.32	4.5		
	031204	I9MT1003R0200-NC2057			2.00	4.25	4.45	6.50	5.65			
	031205	I9MT1003R0250-NC2057			2.50	5.30	5.59	7.66	7.15			
	031206	I9MT1003R0300-NC2057			3.00	+ 0.18 0	5.70	6.92	9.50	10.00		
	031207	I9MT1003R0315-NC2057			3.15	6.70	7.21	8.93	9.00			
12	033201	I9MT12T2R0200-NC2033	TiAlN	K20F	2.00	+ 0.14 0	4.25	4.45	6.64	5.65	2.54	11.73
	033202	I9MT12T2R0250-NC2033			2.50	5.3	5.59	8.11	7.15	13.00		
	033203	I9MT12T2R0315-NC2033			3.15	6.7	7.21	9.63	9.0	14.00		
16	034201	I9MT1603R0400-NC2033	TiAlN	K20F	4.00	+ 0.18 0	8.5	9.06	12.23	11.0	3.18	19.40
	034202	I9MT1603R0500-NC2033			5.00	10.6	11.45	14.2	14.0	19.40		
20	035201	I9MT2004R0630-NC2033	TiAlN	K20F	6.30	+ 0.22 0	13.2	14.63	18.2	18.0	4.76	28.40
	035202	I9MT2004R0800-NC2033			8.00		17.0	18.63	20.44	22.5		28.30
25	036201	I9MT2506R1000-NC2033	TiAlN	K20F	10.00		21.2	23.51	25.8	28.0	6.35	34.20

The quantity of insert per box.:	IC 08	IC 10	IC 12	IC 16	IC 20	IC 25
	5	5	5	2	1	1

DIN332 Form A+B

DIN332
Form A+B

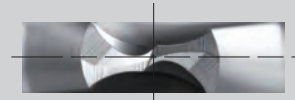
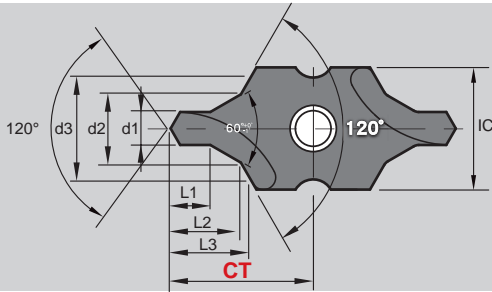

2 cutting flutes design



► For DIN332
Form A+B Center Hole >>

2

i-Center

IC	Code	Parts No.	Coating	Grade	d1	d2	d3	L1	L2	L3	S	CT ±0.025	
08	032011	I9MT08T1B0100-NC5074	Helica	P40	1.00	+0.14 0	2.12	3.15	1.3	2.21	2.51	2.00	7.55
	032012	I9MT08T1B0125-NC5074			2.65		4.0	1.6	2.75	3.14	7.90		
	032013	I9MT08T1B0160-NC5074			3.35		5.0	2.0	3.46	3.93	8.40		
	032014	I9MT08T1B0200-NC5074			4.25		6.3	2.5	4.39	4.98	9.10		
10	031000	I9MT1003B0100-NC2057	AlTiN+ TiSiN	P35	1.00	+0.14 0	2.12	3.15	1.3	2.21	2.51	3.00	12.35
	031001	I9MT1003B0125-NC2057			2.65		4.0	1.6	2.75	3.14			
	031002	I9MT1003B0150-NC2057			3.18		4.50	2.0	3.45	3.84			
	031003	I9MT1003B0160-NC2057			3.35		5.0	2.0	3.46	3.93			
	031004	I9MT1003B0200-NC2057			4.25	6.3	2.5	4.39	4.98				
	031005	I9MT1003B0250-NC2057			5.3	8.0	3.1	5.53	6.28				
	031006	I9MT1003B0300-NC2057			6.46	9.00	4.1	7.10	7.83				
	031007	I9MT1003B0315-NC2057			3.15	+0.18 0	6.7	10.0	3.9	6.90	7.85		
12	033001	I9MT12T2B0200-NC2033	TiAlN	K20F	2.00	+0.14 0	4.25	6.3	2.5	4.39	4.98	2.54	11.73
	033002	I9MT12T2B0250-NC2033			2.50	5.3	8.0	3.1	5.53	6.28	13.0		
	033003	I9MT12T2B0315-NC2033			3.15	6.7	10.0	3.9	6.90	7.85	14.0		
16	034001	I9MT1603B0400-NC2033	TiAlN	K20F	4.00	+0.18 0	8.5	12.5	5.0	8.9	10.03	3.18	19.4
	034002	I9MT1603B0500-NC2033			5.00	10.6	16.0	6.3	11.15	12.68	19.4		
20	035001	I9MT2004B0630-NC2033	TiAlN	K20F	6.30	+0.22 0	13.2	18.0	8.0	13.98	15.33	4.76	28.4
	035002	I9MT2004B0800-NC2033			8.00		17.0	*20	10.1	17.89	18.73		28.3
25	036001	I9MT2506B1000-NC2033	TiAlN	K20F	10.00	+0.22 0	21.2	*25	12.8	22.5	23.57	6.35	34.2

* Notice: The d3 size is different from DIN332 center hole.

The quantity of insert per box.:

IC 08	IC 10	IC 12	IC 16	IC 20	IC 25
5	5	5	2	1	1

DIN332 Form A & ANSI 60°

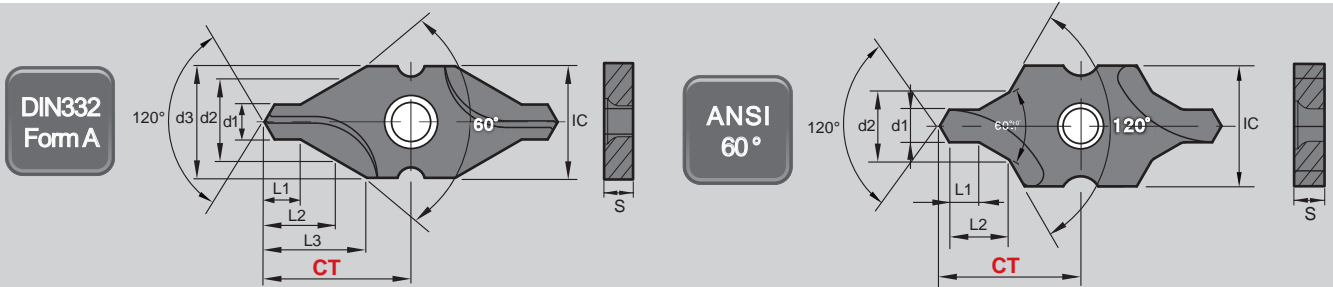

► For DIN332 Form A Center Hole >>

The quantity of insert per box:

IC 08	IC 10	IC 12	IC 16	IC 20	IC 25
5	5	5	2	1	1

2

i-Center

IC	Code	Parts No.	Coating	Grade	d1	d2	d3	L1	L2	L3	S	CT ±0.025
08	032114	I9MT08T1A0200-NC5074	Helica	P40	2.0	4.25	8	2.15	4.10	7.35	2.00	10.5
	032115	I9MT08T1A0250-NC5074			2.5			5.3	2.58	5.00		
	032116	I9MT08T1A0315-NC5074			3.15	6.7	3.23	6.30	7.43			



► For ANSI 60° Center Hole >>

IC	Code	Parts No.	Coating	Grade	Size	d1		d2		L1		L2	S	CT ±0.025	
						mm		mm	mm	mm	mm				
12	033101	I9MT12T2A2-NC2033	TiAlN	K20F	#2	5/64	1.98	+0.14 0	3/16	4.76	5/64	1.98	4.4	2.54	12.6
	033102	I9MT12T2A3-NC2033			#3	7/64	2.78		1/4	6.35	7/64	2.78	5.9		13.8
	033103	I9MT12T2A4-NC2033			#4	1/8	3.18		5/16	7.94	1/8	3.18	7.3		14.25
16	034101	I9MT1603A5-NC2033			#5	3/16	4.76	+0.18 0	7/16	11.11	3/16	4.76	10.3	3.18	20.0
20	035101	I9MT2004A6-NC2033			#6	7/32	5.56		1/2	12.7	7/32	5.56	11.8	27.75	
20	035102	I9MT2004A7-NC2033			#7	1/4	6.35	+0.22 0	5/8	15.88	1/4	6.35	14.6	4.76	28.5
	035103	I9MT2004A8-NC2033			#8	5/16	7.94		3/4	19.05	5/16	7.94	17.6	29.0	
25	036101	I9MT2506A10-NC2033			#10	3/8	9.53	0.98"	25.0	3/8	9.53	22.9	6.35	34.9	

► Measuring Master >>

- Apply on lathe to align the center of work spindle and tool.
- Each insert has just one measuring tip.
- Concentricity: ±0.01mm

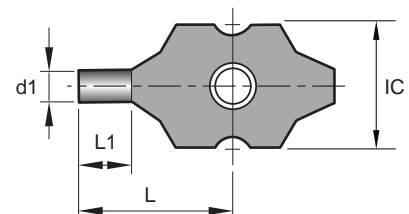

IC	Parts No.	d1	L	L1
08	I9MT08T1-MM	Ø1.9	9.0	3.0
10	I9MT1003-MM	Ø2.9	11.5	5.0
12	I9MT12T2-MM	Ø2.3	13.5	3.5
16	I9MT1603-MM	Ø3.0	19.0	5.0
20	I9MT2004-MM	Ø4.5	26.0	8.0

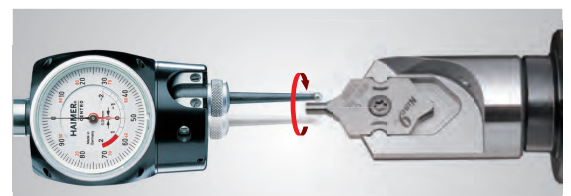

Holders of Indexable Center Drill



▶ Holder >>

- Made of hardened high alloy steel, HRC 53.
- IC08 shank is cylindrical shank. Other shanks are weldon shank.

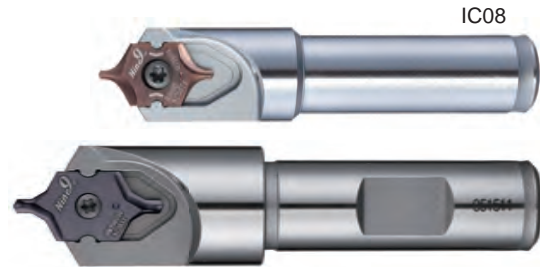
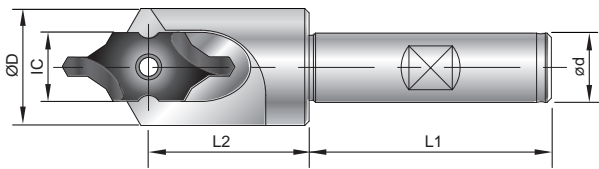

IC	Code	Parts No.	Type	ød	L1	L2	ØD	Screw	Key
08	802002	00-99616-IC08-10F	BC10-IC08F	10	30	18.5	12	*NS-25060 0.9 Nm	NK-T7
	812002	00-99616-IC08-3/8F	BC3/8"-IC08F	3/8"					
10	801002	00-99616-IC10-12F	SB12-IC10F	12	45	24.5	16	*NS-25060 0.9 Nm	NK-T7
12	803002	00-99616-IC12-16F	SB16-IC12F	16	48	30.5	21	NS-30072 2.0 Nm	NK-T9
	813002	00-99616-IC12-5/8F	SB5/8"-IC12F	5/8"					
16	804002	00-99616-IC16-16F	SB16-IC16F	16	48	37	27	NS-35080 2.5 Nm	NK-T15
	814002	00-99616-IC16-5/8F	SB5/8"-IC16F	5/8"					
20	805002	00-99616-IC20-20F	SB20-IC20F	20	50	51	32	NS-50125 5.5 Nm	NK-T20
	815002	00-99616-IC20-3/4F	SB3/4"-IC20F	3/4"					
25	806002	00-99616-IC25-25F	SB25-IC25F	25	56	56	43	NS-50125 5.5 Nm	NK-T20
	816002	00-99616-IC25-1F	SB 1"-IC25F	1"					

*Torque screwdriver is recommended.

▶ Cylindrical Shank with Pre-balanced >>

- Pre-balanced holder enhance the stability of centering to get high accurate profile.
- G6.3 / 10,000 r.p.m.

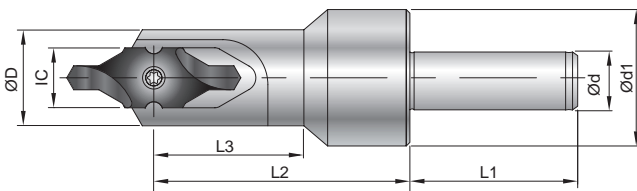

IC	Code	Parts No.	Type	ød	ød1	L1	L2	L3	ØD	Screw	Key
08	802003	00-99616-IC08-10B	BC10-IC08B	10	22	30	33.5	19	12	*NS-25060 0.9 Nm	NK-T7
12	803003	00-99616-IC12-12B	BC12-IC12B	12	34	48	51	30	21	NS-30072 2.0 Nm	NK-T9
16	804003	00-99616-IC16-16B	BC16-IC16B	16	39	48	67	37	27	NS-35080 2.5 Nm	NK-T15
20	805003	00-99616-IC20-20B	BC20-IC20B	20	49	50	86	51	32	NS-50125 5.5 Nm	NK-T20
25	806003	00-99616-IC25-25B	BC25-IC25B	25	59	56	99	56	43	NS-50125 5.5 Nm	NK-T20

*Torque screwdriver is recommended.

Holders of Indexable Center Drill



▶ Square Shank 25 x 25 Right / Left Hand >>

- For used on lathe, clamp by VDI and BMT holders.
- Made of hardened alloy steel, HRC 40.
- Other sizes are available on request.

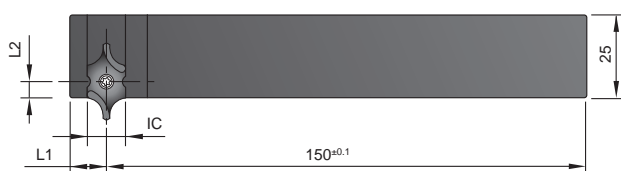

IC	Code	Parts No.	L1	L2	Screw	Key
08	822022	00-99616-IC08-R2525MF	8	3.25	*NS-25060 0.9 Nm	NK-T7
	822012	00-99616-IC08-L2525MF				
12	823022	00-99616-IC12-R2525MF	11	4.9	NS-30072 2.0 Nm	NK-T9
	823012	00-99616-IC12-L2525MF				
16	824022	00-99616-IC16-R2525MF	13	4.9	NS-35080 2.5 Nm	NK-T15
	824012	00-99616-IC16-L2525MF				

*Torque screwdriver is recommended.

▶ Double Flat Shank >> Non-Stock Item

- Used on lathe.
- Double flat shank design for tool holder with side lock flat.
- 180° for insert at top, 90° for insert at front.

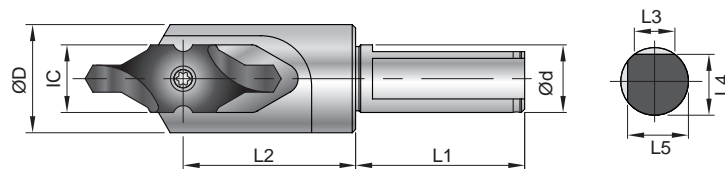

IC	Code	Parts No.	Type	Ød	L1	L2	L3	L4	L5	ØD	Screw	Key
08	802004	00-99616-IC08-10S	SL10-IC08S	10	30	18.5	6	9	9	12	*NS-25060 0.9 Nm	NK-T7
12	803004	00-99616-IC12-16S	SL16-IC12S	16	48	30.5	9.33	14.5	14.5	21	NS-30072 2.0 Nm	NK-T9
16	804004	00-99616-IC16-16S	SL16-IC16S	16	48	37	9.33	14.5	14.5	27	NS-35080 2.5 Nm	NK-T15
20	805004	00-99616-IC20-20S	SL20-IC20S	20	50	51	12	18	18	32	NS-50125 5.5 Nm	NK-T20
25	806004	00-99616-IC25-25S	SL25-IC25S	25	56	56	13.57	23	23	43	NS-50125 5.5 Nm	NK-T20

*Torque screwdriver is recommended.

2

i-Center

Center Height Adjusting Sleeve

► Principle >>

- Designed for adjusting Center Height of center drills, NC spot drills, reamers and taps on the CNC lathes.
- The main body is made from two sleeves. The inner sleeve is to hold and lock the cutting tool.
- Its center is inclined to the outer sleeve. When the inner sleeve is pushed or pulled, the cutting tool's center height is adjusted to lower or higher position.

► Parts No.:00-99600-320H >>

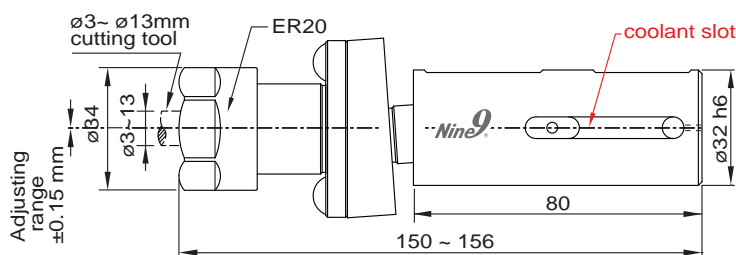

► Type : SB32-IDER20

► Parts No.:00-99600-400H >>

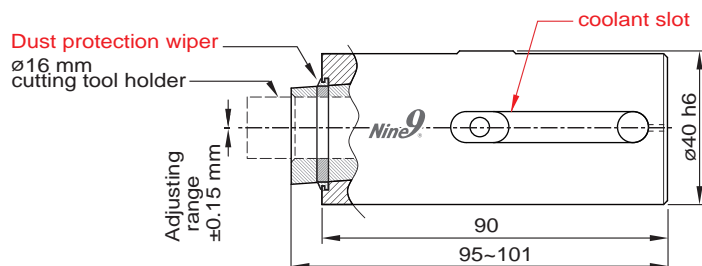

► Type : SB40-ID16

► Applications >>

- Used when the CNC lathes need to adjust the center height.
- This sleeve can be clamped by VDI 40, VDI 50 E2 tool holders, and other types internal turning tool holders.
- Center height adjusting range: ± 0.15 mm (.006").
- Total axial movement is 6mm (.236").

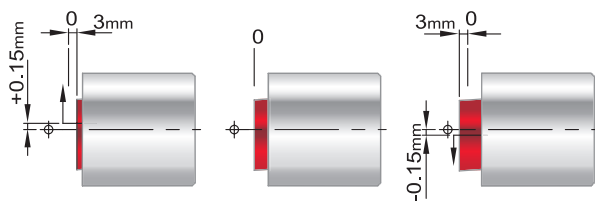

Tightening screw 4mm Hex key

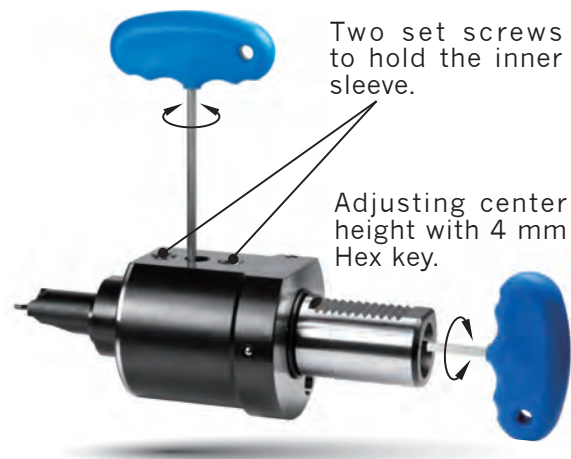

Performance

► Profit by making the right choice >>

- High speed and feed rate reduce cutting time.
- The unique design increases tool life and reduces change over time.

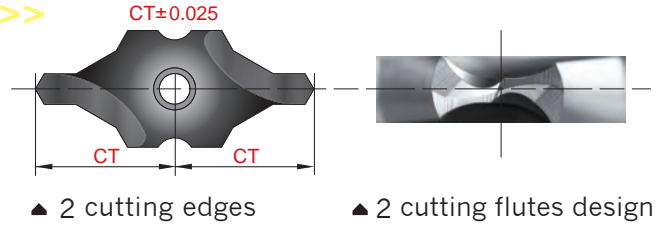

► Comparison >>

- Workpiece : Low carbon alloy steel, 850 N/mm²
- Machine: VMC BT40 with internal coolant

Diameter of tool : Ø3.15 mm Depth of drilling : 7.2 mm				
Comparison		i-Center	HSS Center Drill (TiN Coating)	Solid Carbide Center Drill
Cutting speed	m/min.	65	17	65
Spindle speed	r.p.m.	6570	1718	6570
Feed rate f =	mm/rev.	0.12	0.02	0.1
Feed rate F=	mm/min.	788.4	34.4	657
Coolant	Emulsion	External / Internal	External	External
Drilling time	sec.	0.55	12.5	0.65
Holes of drilling per edge		7000	700	5000

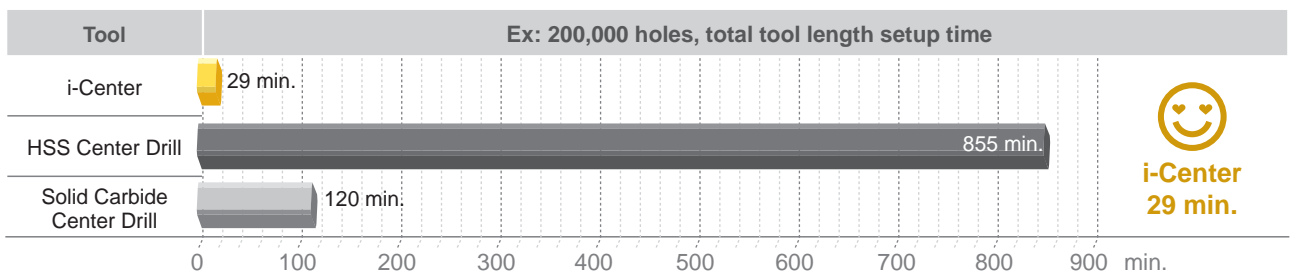
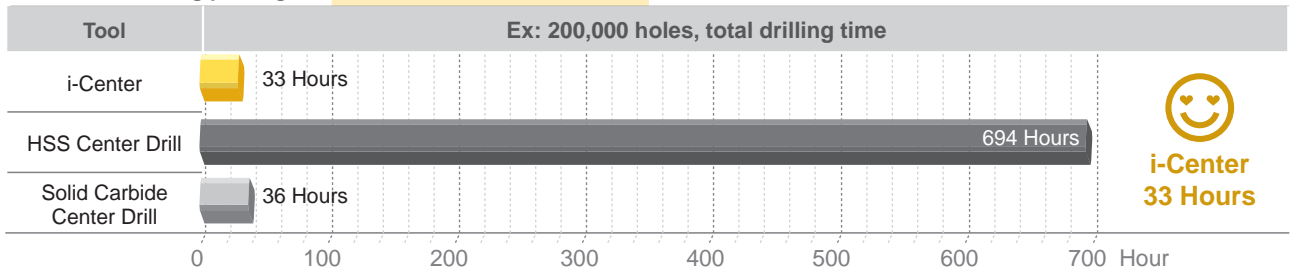

► Surface finish >>

i-Center Insert	Material SCM440	
I9MT1603B0500 NC2033	Vc	60 m/min.
	S	3800 r.p.m.
	f	0.1 mm/rev.
	F	380 mm/min.
	Ap	13.5 mm



```

Perthometer M1
Object
Name
#
Lt 5.600 mm
Ls Standard 0.205 µm
Lc 0.800 mm
Ra 0.562 µm
Rz 3.26 µm
Rmax 3.61 µm
R Pc(0.5,-0.5) 68 %c

R Profile
Lc 0.800 mm
VER 2.50 µm
    
```

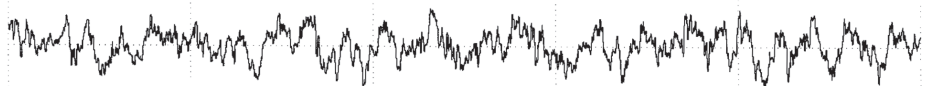

i-Center Enquiry Form

The following information should be checked while discussing with customer.

Machine	
Machine Type	
Spindle Speed	Max. r.p.m.
Power of Spindle motor	<input type="checkbox"/> KW <input type="checkbox"/> HP
Coolant supply	<input type="checkbox"/> NO
	<input type="checkbox"/> If yes, <input type="checkbox"/> External <input type="checkbox"/> Internal bar(psi)
Current tool	
Cutting Speed	<input type="checkbox"/> HSS <input type="checkbox"/> Solid Carbide m/min. SFM
Others	
Feed Rate	mm/rev. inch/rev.
Work Piece	
Material code	
Center hole type	<input type="checkbox"/> R <input type="checkbox"/> A <input type="checkbox"/> B <input type="checkbox"/> C <input type="checkbox"/> Other as attached drawing
Other request	<input type="checkbox"/> Surface roughness <input type="checkbox"/> Tolerance(see below)

► Special Tool holder shank dimensions >>

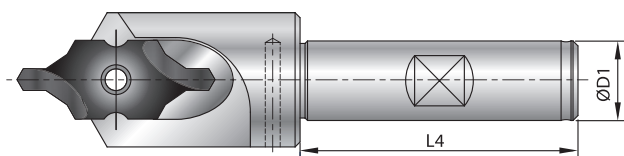

Dimension Table	A1	A2	A3	ød1	ød2	ød3
Dimension						
Tolerance	---	+0° -1°	±1°	±0.05	±0.05	---

Dimension Table	L1	L2	L3	R	øD1	L4
Dimension						
Tolerance	±0.05	±0.05	±0.05	±0.5	h6	---

► DIN332 Form D >> Non-Stock Item



- M3, M4 Counterbore Insert, K20F grade, TiAlN coated.

Part No.	d1	d2	d3	d4	L1	L2	L3
I9MT12T2M03-NC2033	3.40	4.40	6.00	8.00	3.00	4.04	5.04
I9MT12T2M04-NC2033	4.50	5.50	8.00	10.0	4.00	5.21	6.21

► Center hole dimension >>

- Please provide workpiece drawing
- One of following type should be chosen.

Type R

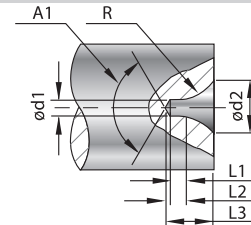

Type A

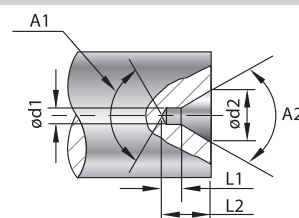

Type B

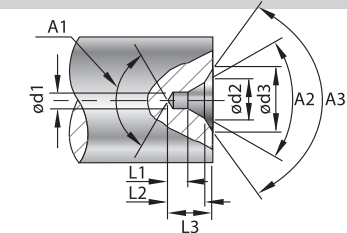

Type C

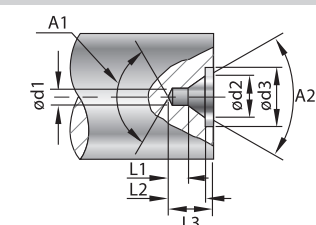

Other

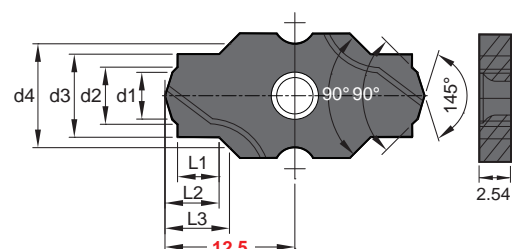
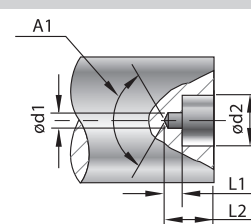

Technical Standard ISO 2541-1972 / DIN332

► 60° Center holes >>

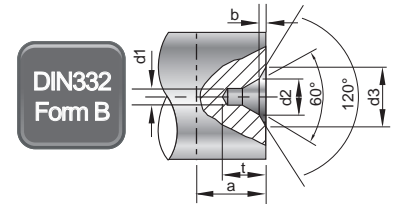
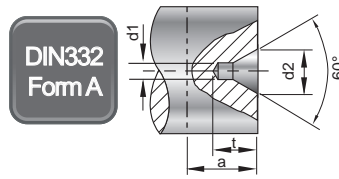
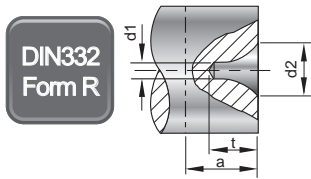

STD	DIN332 Form R ISO 2541-1972			DIN332 Form A ISO 866-1975			DIN332 Form B ISO 2540 1973					
	d1	d2	t	a	d2	t	a	d2	b	d3	t	a
1		2.12	1.9	3	2.12	1.9	3	2.12	0.3	3.15	2.2	3.5
1.25		2.65	2.3	4	2.65	2.3	4	2.65	0.4	4	2.7	4.5
1.6		3.35	2.9	5	3.35	2.9	5	3.35	0.5	5	3.4	5.5
2		4.25	3.7	6	4.25	3.7	6	4.25	0.6	6.3	4.3	6.6
2.5		5.3	4.6	7	5.3	4.6	7	5.3	0.8	8	5.4	8.3
3.15		6.7	5.8	9	6.7	5.9	9	6.7	0.9	10	6.8	10
4		8.5	7.4	11	8.5	7.4	11	8.5	1.2	12.5	8.6	12.7
5		10.6	9.2	14	10.6	9.2	14	10.6	1.6	16	10.8	15.6
6.3		13.2	11.4	18	13.2	11.5	18	13.2	1.4	18	12.9	20
8		17	14.7	22	17	14.8	22	17	1.6	22.4	16.4	25
10		21.2	18.3	28	21.2	18.4	28	21.2	2	28	20.4	31

* a: Minimum material will be cut. If the center hole will be removed after turning or grinding. (mm/inch)

► Form R center hole apply for >>

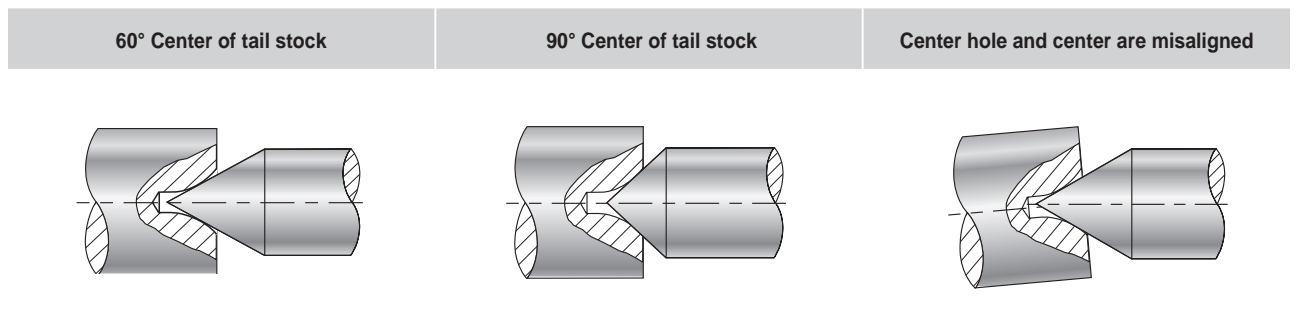

► Form B center hole apply for >>

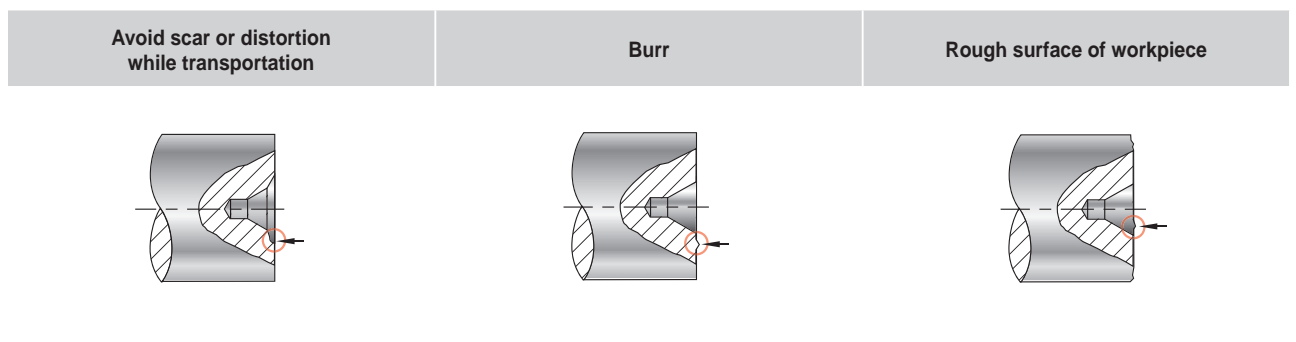

i-Center Applications

► Tip >>

- Various centering applications and products - shafts of engine, transmission gear, bearings, motors, grinding parts, spindles, gear reducers, cooling fan, universal joints...
- Special forms for other applications also available on request.

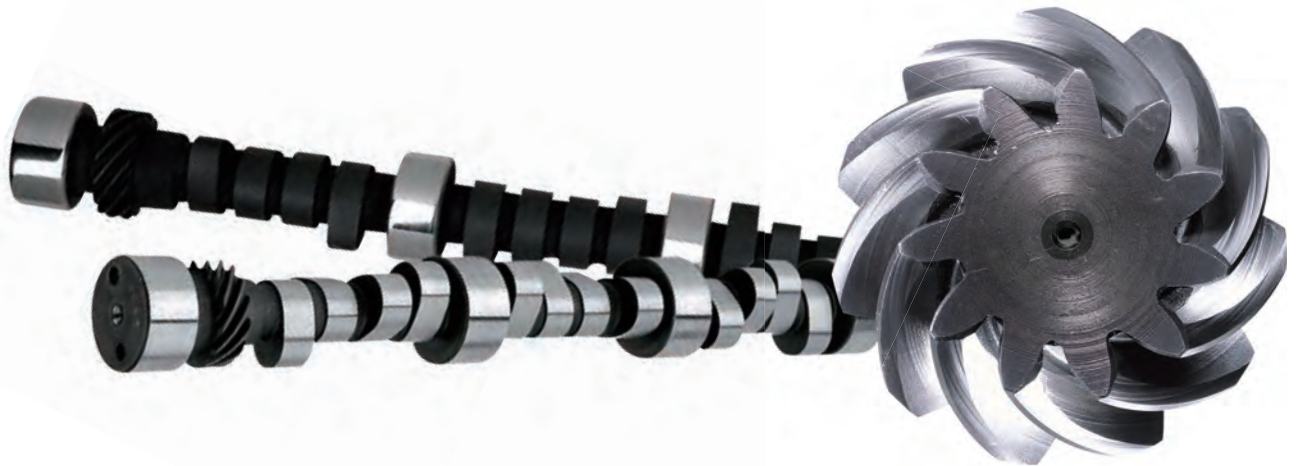

2
i-Center

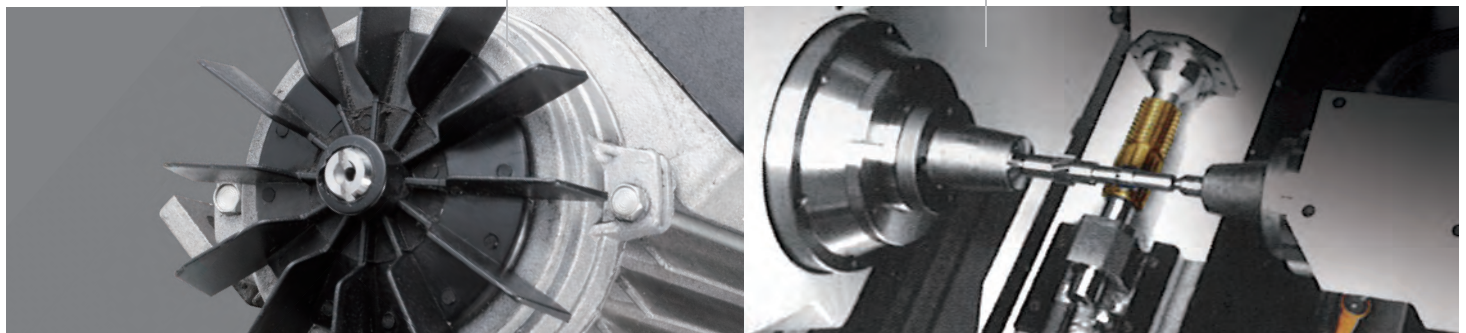



Technical Guide

► Before you start, please pay attention the following conditions >>

2

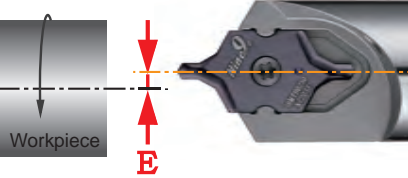
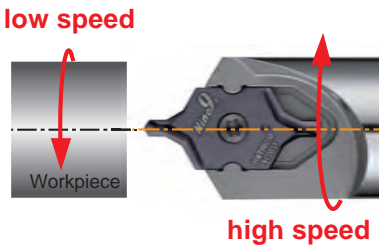
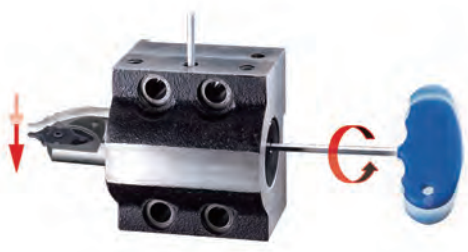
i-Center

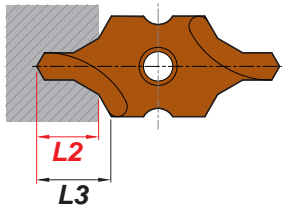
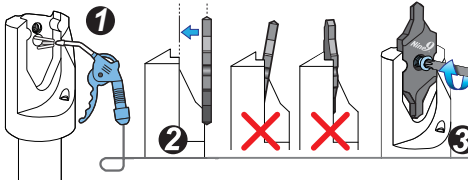
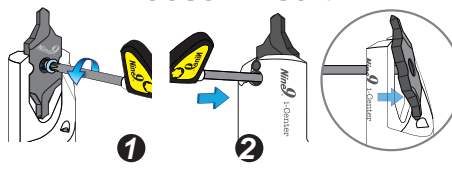
Center misalignment	Driving Tool	Center height adjusting sleeve
<p>E must be < 0.02mm.</p> 	<p>low speed : high speed 1 : 3</p> 	<p>When CNC lathe turret center is misaligned ≥ 0.15mm, please use center height adjusting sleeve. (See page 61)</p> 
Internal coolant	DIN 332 Form A+B	Clamping insert
<p>Internal coolant is recommended.</p> 	<p>Reduce 30% of Spindle speed and keep same feed rate (mm/rev.) while depth L2 is reached.</p> 	 <p>Loosen insert</p> 

Metric	Inch
$d1 = \text{diameter -mm}$	$d1 = \text{diameter-inch}$
$S = \frac{Vc \times 1000}{\pi \times d1}$	$S = \text{Spindle Speed-r.p.m.}$
$Vc = \text{Cutting Speed -m/min.}$	$SFM = \frac{Vc \text{ (m/min.)} \times 3.28}{\text{Surface Speed-ft./min.}}$
$F = S \times f$	$F = \text{IPR} \times \text{inch/rev.}$
$f = \text{mm/rev.}$	$f = \text{inch/rev.}$
$F = \text{mm/min.}$	$F = \text{inch/min.}$

Cutting Data

▶ Ø1~Ø3.15 (A2~A4)

Workpiece material	Vc (m/min.)	d1 (pilot dia.)	IC08 / IC10		IC12			
			Ø1~1.25	Ø1.6~3.15	Ø2 (A2)	Ø2.5 (A3)	Ø3.15 (A4)	
P Carbon steel C<0.3%	< 80	S r.p.m.	2000 ~ 10000	1600 ~ 8000	1600 ~ 8000	1400 ~ 7000	1200 ~ 6000	● ○
		f mm/rev.	0.02~0.03~0.05	0.03~0.05~0.06	0.04~0.06~0.08	0.06~0.08~0.10	0.08~0.10~0.12	● ○
P Carbon steel C>0.3%	< 70	S r.p.m.	2000 ~ 9000	1600 ~ 7200	1600 ~ 7200	1400 ~ 6300	1200 ~ 5400	● ○
		f mm/rev.	0.02~0.03~0.05	0.03~0.04~0.05	0.03~0.04~0.05	0.06~0.08~0.10	0.08~0.10~0.12	● ○
P Low alloy steel C<0.3%	< 65	S r.p.m.	2000 ~ 8000	1600 ~ 6400	1600 ~ 6400	1400 ~ 5600	1200 ~ 4800	● ○
		f mm/rev.	0.01~0.02~0.04	0.02~0.03~0.05	0.02~0.03~0.05	0.04~0.06~0.08	0.06~0.08~0.10	● ○
P High alloy steel	< 60	S r.p.m.	1000 ~ 6000	800 ~ 4800	800 ~ 4800	700 ~ 4200	600 ~ 3600	● ○
		f mm/rev.	0.01 ~ 0.02	0.01~0.02~0.04	0.01~0.02~0.04	0.02~0.04~0.06	0.04~0.06~0.08	● ○
M Stainless steel	< 20	S r.p.m.	1000 ~ 3000	800 ~ 2400	800 ~ 2400	700 ~ 2100	600 ~ 1800	● ○
		f mm/rev.	0.003 ~ 0.01	0.005 ~ 0.02	0.01 ~ 0.02	0.01~0.02~0.03	0.02~0.03~0.05	≥ 5 bar
K Cast Iron	< 70	S r.p.m.	2000 ~ 9000	1600 ~ 7200	1600 ~ 7200	1400 ~ 6300	1200 ~ 5400	Air
		f mm/rev.	0.01~0.02~0.04	0.02~0.04~0.06	0.02~0.04~0.06	0.04~0.06~0.08	0.06~0.08~0.10	Air
N Non-ferrous metal	< 200	S r.p.m.	6000 ~ 20000	4800 ~ 16000	4800 ~ 16000	4200 ~ 14000	3600 ~ 12000	● ○
		f mm/rev.	0.01~0.02~0.03	0.01~0.02~0.04	0.01~0.02~0.04	0.02~0.03~0.05	0.02~0.04~0.06	● ○

● Best ○ Possible



▶ Ø4~Ø10 (A5~A10)

Workpiece material	Vc m/min.	d1 (pilot dia.)	IC16		IC20		IC25	
			Ø4 (A5)	Ø5 (A6)	Ø6.3 (A7)	Ø8 (A8)	Ø10 (A10)	
P Carbon steel C<0.3%	< 80	S r.p.m.	1000 ~ 5000	900 ~ 4500	800 ~ 4000	700 ~ 3500	600 ~ 3000	● ○
		f mm/rev.	0.08~0.12~0.14	0.10~0.12~0.16	0.10~0.14~0.16	0.12~0.15~0.18	0.14~0.18~0.20	● ○
P Carbon steel C>0.3%	< 70	S r.p.m.	1000 ~ 4500	900 ~ 4050	800 ~ 3600	700 ~ 3150	600 ~ 2700	● ○
		f mm/rev.	0.08~0.12~0.14	0.10~0.12~0.16	0.10~0.14~0.16	0.12~0.15~0.18	0.14~0.18~0.20	● ○
P Low alloy steel C<0.3%	< 65	S r.p.m.	1000 ~ 4000	900 ~ 3600	800 ~ 3200	700 ~ 2800	600 ~ 2400	● ○
		f mm/rev.	0.06~0.08~0.10	0.08~0.10~0.12	0.08~0.12~0.14	0.10~0.14~0.16	0.12~0.16~0.20	● ○
P High alloy steel	< 60	S r.p.m.	500 ~ 3000	450 ~ 2700	400 ~ 2400	350 ~ 2100	300 ~ 1800	● ○
		f mm/rev.	0.04~0.06~0.08	0.06~0.08~0.10	0.08~0.10~0.12	0.10~0.14~0.16	0.10~0.14~0.16	● ○
M Stainless steel	< 25	S r.p.m.	500 ~ 1500	450 ~ 1350	400 ~ 1200	350 ~ 1050	300 ~ 900	● ○
		f mm/rev.	0.02~0.04~0.06	0.02~0.04~0.06	0.04~0.06~0.08	0.04~0.06~0.08	0.05~0.07~0.10	≥ 5 bar
K Cast Iron	< 70	S r.p.m.	1000 ~ 4500	900 ~ 4050	800 ~ 3600	700 ~ 3150	600 ~ 2700	Air
		f mm/rev.	0.06~0.08~0.10	0.08~0.10~0.12	0.08~0.12~0.14	0.10~0.14~0.16	0.12~0.16~0.18	Air
N Non-ferrous metal	< 200	S r.p.m.	3000 ~ 10000	2700 ~ 9000	2400 ~ 8000	2100 ~ 7000	1800 ~ 6000	● ○
		f mm/rev.	0.02~0.04~0.06	0.04~0.06~0.08	0.04~0.06~0.08	0.06~0.08~0.10	0.06~0.08~0.10	● ○

● Best ○ Possible