



NC Helix Drill >>>

The Expert Of Swarfs Control

P M K N S H

▶ **Two Types Of Shank, Drilling Depth Up To 8xDc**

- Cylindrical shank - Apply external coolant.
- Patented screw fit -With center coolant hole.



Features >>>

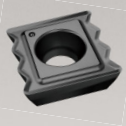

▶ **Serrated Cutting Edge.**

- One insert is able to cut different materials.
- Special insert geometry is able to cut different materials and eliminate swarf and vibration problems while drilling difficult material or deeper holes. Excellent swarfs control for providing safe and smooth chip removal for modern automation.
- 2 cutting edges insert

▶ **Only Six Tools For Making Ø13~Ø65mm Holes From Solid.**

- Saving your tool inventory and cost!
- No need to peck drill or dwell in operation even machine without internal coolant.

▶ **20° Ramping Angle, Either Linear Or Circular Ramping.**

- Cuts material by helical interpolation, maximum ramping angle is 20°.

▶ **Low Spindle Power Is Required, Easy To Cut, Not Only A Drill, But An End Mill Too.**



Applications

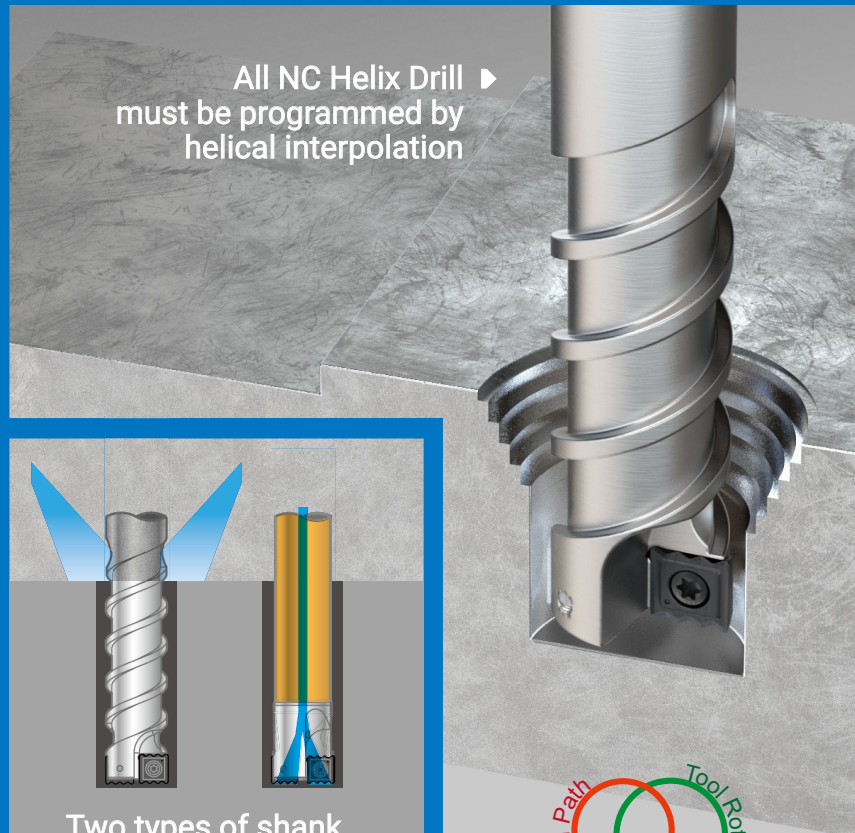

All NC Helix Drill ▶
must be programmed by
helical interpolation



20°
max.
ramping
angle

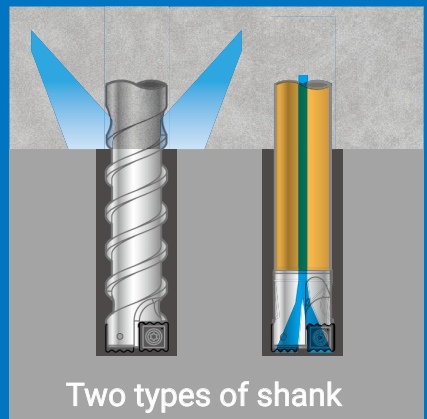

Two types of shank

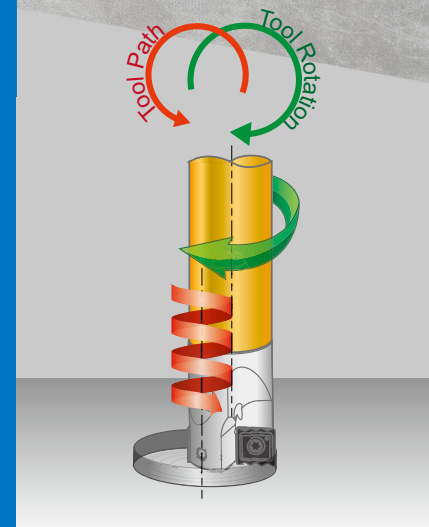

“

- One tool performs multiple applications.
- Rough Milling, Drilling & Slotting.
- Excellent swarf removal. ”



Short & small chips

6

NC Helix Drill

NC Helix Drill Features

▶ Reduce your tool inventory >> Low Cost! Economy!

- Each holder can machine different diameters and hole depths, saving your tool inventory and cost!
- No need to peck drill or dwell in operation even machine without internal coolant.

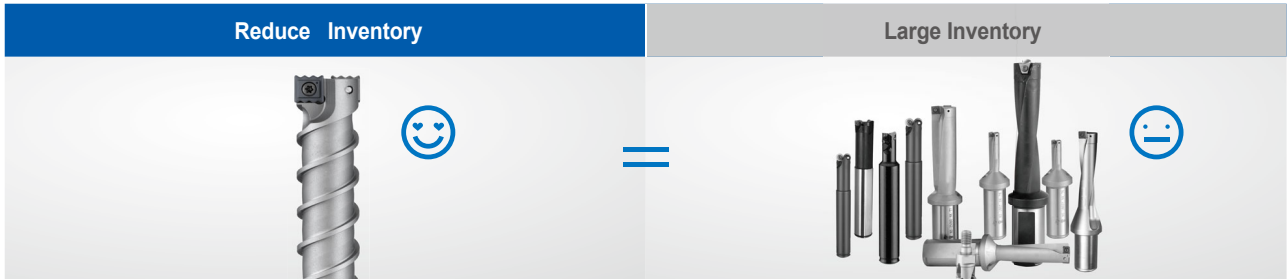

▶ Lower spindle power consumption >> Easy to cut!

- Thanks to the small cutting load of the serrated cutting edge and helical interpolation lower power consumption. Work quicker, smarter and achieve better results.
- Circular ramping milling, maximum ramping angle is 20°.
- For example: tool HD27 machining Ø50 mm hole, 9 mm pitch for aluminum, 6 mm pitch for carbon steel.

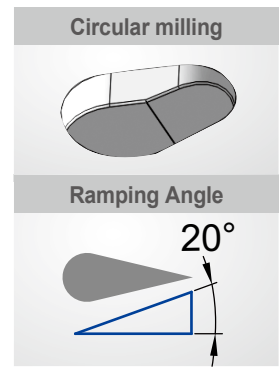

▶ Just six tools for drilling Ø13~ Ø 65 mm or larger >>



- Cuts by helical interpolation.
- Each holder can machine different diameters and hole depths.
- Enlarger hole is adaptable by using 99323 internal coolant cutter.

▶ Special insert geometry >> exceptional swarfs control.

- Serrated cutting edge makes the chips short and small, and easier to evacuate.
- Eliminate swarf and vibration problems while drilling difficult material or deeper holes.
- Excellent swarfs control for providing safe and rational chip removal for modern automation.

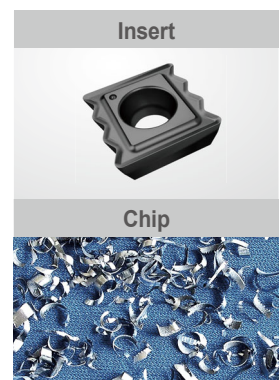

► **Functions in variable conditions >>**
It's so easy!

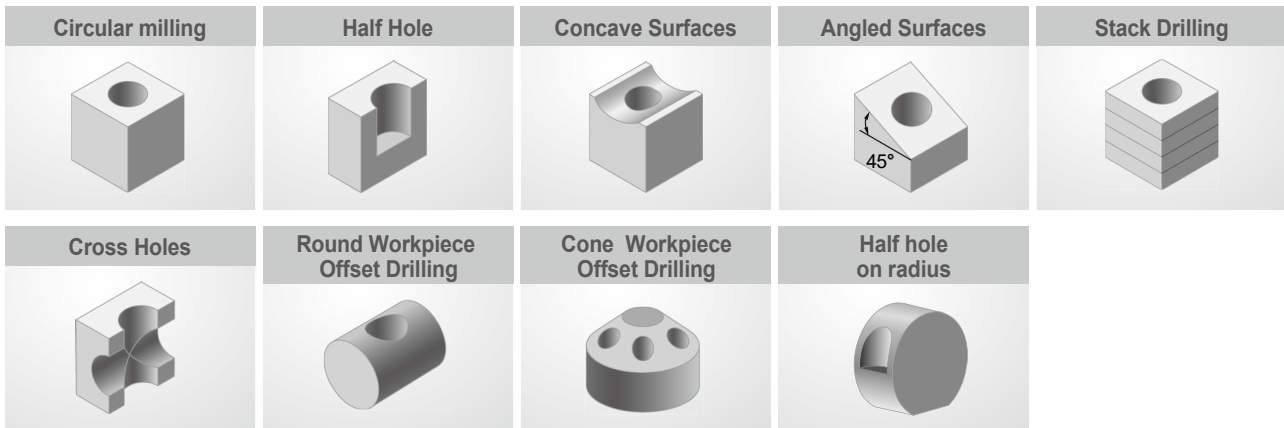

► **Roughness Measuring >>**

- Making a flatness at bottom just by NC program, easy and smart!

Workpiece Application

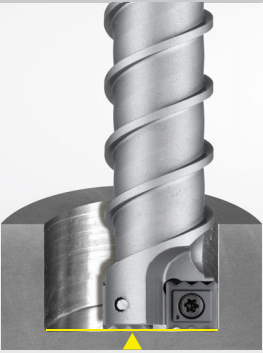

Make "One more turn" after reached the depth.
 Ex :
 G03 I-1.5 Z-30 P5
 G03 I-1.5 <make one more turn >
 G01 X0 Y0 < afterward, let tool back to center of hole >

Perthometer M1	
Object Name	
#	
Lt	5.600 mm
Ls Standard	2.5 μm
Lc	0.000 mm
Ra	1.476 μm
Rz	6.91 μm
Rmax	7.71 μm
RPc(0.5,-0.5)	48 /c
R Profile	
Lc	0.000 mm
VER	2.50 μm

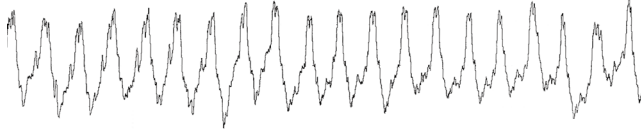

Flatness

► **One tool performs multiple applications >>**

Not only a drill, but an end mill tool. Small path radius to cut hole, step hole, various shape of cavity on different material.

Less inventory of different sizes of drills and indexable end mills.

Replace your end mill by NC Helix Drill. Make the impossible become possible!



NC Helix Drill

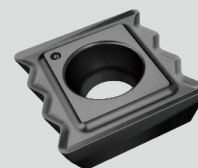
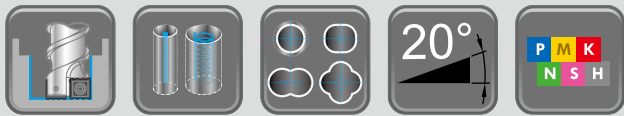

▶ Inserts >>

- NC5075** : • Good for steel with heat treatment up to 50HRC.
 - Reduce heat and tool wear.
 - Long tool life.

- NC5072** : • General purpose.
 - Suitable for almost all kind of steel, stainless steel and Titanium.

- NC2032** : • High performance cutting.
 - Special good for cast iron and hardened material < HRC50°.

Code	Parts No.	Grade	Coating	Dimensions			Screw	Key
				L	S	Re		
041041	01-N9MX04T002	NC5075	P40	4.75	1.8	0.2	*NS-18037 0.6Nm	NK-T6
041021		NC5072	P40					
041001		NC2032	K20F					
042041	01-N9MX05T103	NC5075	P40	5.75	2.0	0.3	*NS-20045 0.6Nm	NK-T6
042021		NC5072	P40					
042001		NC2032	K20F					
043041	01-N9MX070204	NC5075	P40	7.5	2.4	0.4	*NS-25045 0.9Nm	NK-T7
043021		NC5072	P40					
043001		NC2032	K20F					
044041	01-N9MX100306	NC5075	P40	10.0	3.18	0.6	NS-30072 2.0Nm	NK-T9
044021		NC5072	P40					
044001		NC2032	K20F					
045041	01-N9MX12T308	NC5075	P40	12.5	3.97	0.8	NS-35080 2.5Nm	NK-T15
045021		NC5072	P40					
045001		NC2032	K20F					

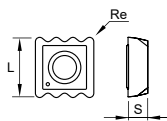

*Torque screwdriver is recommended.

▶ Cylindrical Shank >>

- Made from hardened high alloy steel 48 HRC.
- Unique helical groove design generates chip-removing coolant stream.
- Designed for CNC machine with external coolant.

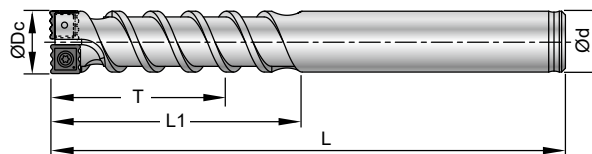

Code	Parts No.	Type	Capable of drill dia. mm		ØDc	T	L1	L	Ød	Insert type	Max. ramping angle
			Dmin.	Dmax.							
401001	00-99321-010-1320	BC10-HD11-1320	13	20	11	30	40	80	10	N9MX04T002	20°
402001	00-99321-012-1525	BC12-HD13-1525	15	25	13	36	50	100	12	N9MX05T103	20°
403001	00-99321-016-2030	BC16-HD17-2030	20	30	17	50	60	110	16	N9MX070204	20°
404001	00-99321-020-2540	BC20-HD22-2540	25	40	22	60	70	125	20	N9MX100306	20°
405001	00-99321-025-3050	BC25-HD27-3050	30	50	27	75	85	165	25	N9MX12T308	20°

▶ Side Lock Shank >>

- Made from hardened high alloy steel 48 HRC.
- With internal coolant
- Special size is available on request.

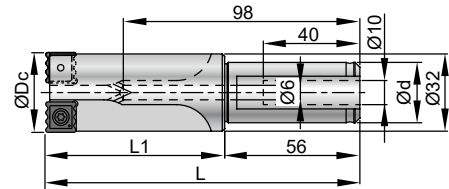

Code	Parts No.	Type	Capable of drill dia. mm		ØDc	L	L1	Ød	Max. Depth	Insert type	Max. ramping angle
			Dmin.	Dmax.							
405002	00-99321-025-4265	SL25-HD33-4265	42	65	33	130	74	25	50	N9MX12T308	9°

▶ Screw Fit Cutter >>

- Made from hardened high alloy steel 42 HRC.
- With internal coolant.
- Standard screw-fit body adapts to almost any kinds of the screw-fit tool holder or extension bar in the market.
- Possible to apply for enlarge hole.

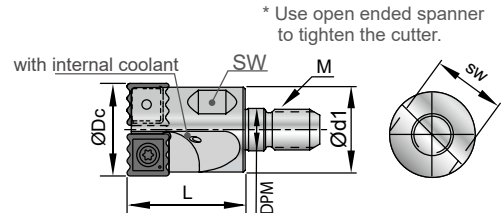

Code	Part No.	Type	Capable of drill dia. mm		ØDc	L	M	DPM	Ød1	SW	Insert type	Max. ramping angle
			Dmin.	Dmax.								
421001	00-99323-010-1320	M05-HD11-1320	13	20	11	20	M5	5.5	10	8	N9MX04T002	20°
422001	00-99323-012-1525	M06-HD13-1525	15	25	13	25	M6	6.5	12	10	N9MX05T103	20°
423001	00-99323-016-2030	M08-HD17-2030	20	30	17	25	M8	8.5	16	14	N9MX070204	20°
424001	00-99323-020-2540	M10-HD22-2540	25	40	22	30	M10	10.5	20	18	N9MX100306	20°
425001	00-99323-025-3050	M12-HD27-3050	30	50	27	35	M12	12.5	25	23	N9MX12T308	20°

* Special size is available by request.

Extension Bar

▶ Steel Type >>

- T is the maximum overhang length.
- With internal coolant hole.

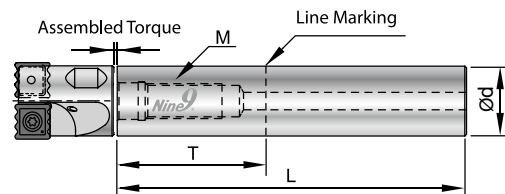

Code	Parts No.	Type	Ød	T	L	M	Assembled Torque
970100	00-99801-10S	BC10-075M05S	10	25	75	M5xP0.8	6.5 Nm
970122	00-99801-12S	BC12-075M06S	12	25	75	M6xP1.0	11.0 Nm
970161	00-99801-16S	BC16-090M08S	16	35	90	M8xP1.25	25.0 Nm
970202	00-99801-20S	BC20-100M10S	20	40	100	M10xP1.5	50.0 Nm
970253	00-99801-25S	BC25-120M12S	25	50	120	M12xP1.75	60.0 Nm

▶ Solid Carbide Type >>

- T is the maximum overhang length.
- With internal coolant hole.

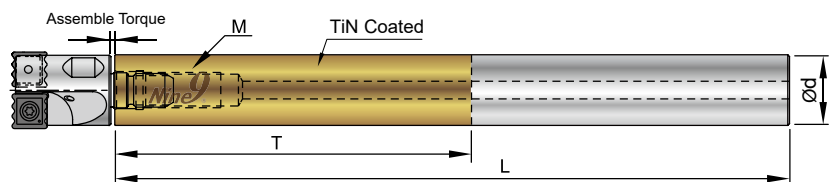

Code	Parts No.	Type	Ød	T	L	M	Assembled Torque
980102	00-99801-10W	BC10-100M05W	10	50	100	M5xP0.8	6.5Nm
980122	00-99801-12W	BC12-100M06W	12	60	100	M6xP1.0	11.0Nm
980143	00-99801-14W	BC14-120M08W	14	70	120	M8xP1.25	25.0Nm
980164	00-99801-16W	BC16-150M08W	16	80	150	M8xP1.25	25.0Nm
980184	00-99801-18W	BC18-150M10W	18	90	150	M10xP1.5	50.0Nm
980205	00-99801-20W	BC20-200M10W	20	100	200	M10xP1.5	50.0Nm
980255	00-99801-25W	BC25-200M12W	25	125	200	M12xP1.75	60.0Nm

Technical Guide

► Programming conditions

Blind Hole *

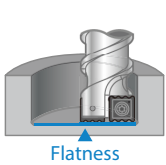

Through Hole *

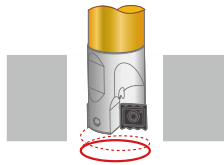

Step Hole

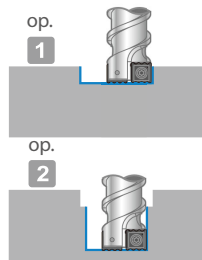

Pre-bored work piece

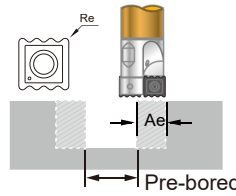

External coolant Min. 5 bar



Internal coolant Min. 10 bar

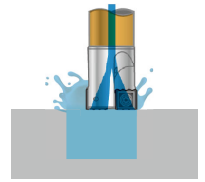

*50% feedrate reduced at the bottom or last circular of cutting.

► For enlarge hole

Minimum and Maximum Ae for programming a pre-bored hole

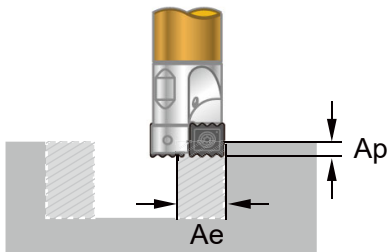

Max. Ae = Dc - (Rex2)
Min. Ae = 1/3 insert length (L)
Max. ap < 3/4 of insert length

Insert type	Re	Min. Ae	Max. Ae	Max. Ap
N9MX04T002	0.2	1.6	10.6	3.5
N9MX05T103	0.3	2.0	12.4	4.3
N9MX070204	0.4	2.5	16.2	5.6
N9MX100306	0.6	3.3	20.8	7.5
N9MX12T308	0.8	4.2	25.4	9
N9MX12T308*	0.8	4.2	31.4*	9

(* for 99321-025-4265)

NC Helix Drill	Cutting Parameters (S & F)	Formula
	$S = \frac{Vc \times 1000}{Dc \times \pi} \text{ r.p.m.}$	Dc = Dia. of drill mm
	$F = S \times fz \times Z \text{ mm/min.}$	D = Dia. of hole mm
	$d = D - Dc \text{ mm}$	L = Depth of drilling mm
	$I = \frac{(D-Dc)}{2} \text{ mm}$	Vc = Cutting speed m/min.
	Cutting time (T)	S = Spindle speed r.p.m.
	$T = \frac{\pi \times d \times L \times 60}{F \times P} \text{ sec.}$	I = Circular radius mm
	Chip removal Volume rate (Q)	fz = Feed rate mm/tooth
	$Q = \frac{\pi \times D^2 \times L \times 60}{4 \times 1000 \times T} \text{ cm}^3 / \text{min.}$	F = Table feed rate mm/min.
		d = Circular diameter (D-Dc) mm
		P = Pitch of helical interpolation mm
	T = Cutting time sec.	
	Q = Chip removal volume rate cm ³ / min.	
	Z = Insert tooth	

► Spindle power

The Feed rate(Fc) may be adjusted by the power factor(PF) of below:

$$F_c = F \times PF \text{ (mm/min.)}$$

Spindle Type	BT-30 Small power			BT-40 Medium power			BT-50 Big power		
	Spindle Power (KW)	< 5	7	10	12	16	20	22	25
Power Factor (PF)	0.8	0.85	0.9	0.95	1	1.05	1.1	1.15	1.2
Pitch (P)	Lower pitch			Medium pitch			Large pitch		

Remarks:

Fc: Adjusted Feed rate for real cutting

Pitch(P) can be selected according to spindle power.

► 99323 screw fit cutter assembly

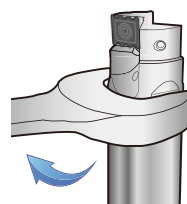

To ensure a secure fit, use a spanner to tighten the cutter until there is no gaps visible.

Part No.	Assembled Torque
99323-010-1320	6.5 Nm
99323-012-1525	11.0 Nm
99323-016-2030	25.0 Nm
99323-020-2540	50.0 Nm
99323-025-3050	60.0 Nm

► Apply only helical interpolation or ramping down feed only!

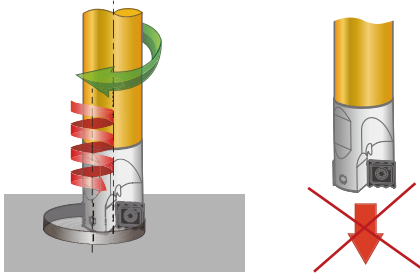

Step 1: Choose Cutting speed(Vc), feed rate(f) and Pitch(P) on the cutting data tables (page 3&4). The feed rate and Pitch can be adjusted depend on the spindle power, please see page 6-114.

Step 2: Decide circular radius I ($I = (D - D_c) / 2$)
For enlarge hole, decided Ae as page 6-114.

Step 3: Programming helical interpolation program according to CNC controller.

This sample program is written for general condition of the CNC controller.
The NC program can be generated by most of the CAD/CAM system.

► Example

1 Programming a blind hole

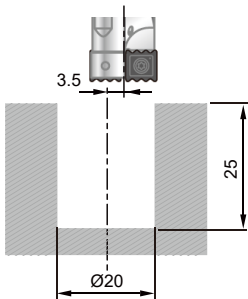

Material	N AL6061T6
Holder	00-99321-012-1525
Insert	01-N9MX05T103-NC5072
Dc	ø13 mm
Vc	306 m/min.
f	0.065 mm/tooth
P	3 mm
I	$(20-13)/2 = 3.5$ mm

```
G00 G90 X3.5 Y0.
S7500 M03
G43 H01 Z30. M08
Z5.
G01 Z2. F500.
G03 I-3.5 Z-1. F975
G03 I-3.5 Z-4.
G03 I-3.5 Z-7.
G03 I-3.5 Z-10.
G03 I-3.5 Z-13.
G03 I-3.5 Z-16.
G03 I-3.5 Z-19.
G03 I-3.5 Z-22.
G03 I-3.5 Z-25.
G01 X0. Y0.
G00 G90 Z5. M09
G00 G90 Z30. M05
G28 G91 Z0.
```

2 Programming a step hole

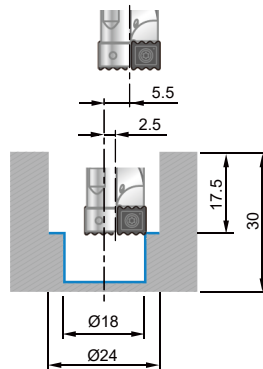

Material	P SCM440
Tool holder	00-99323-012-1525
Insert	01-N9MX05T103-NC5072
Dc	ø13 mm
Vc	100 m/min.
For D1	ø24 mm
f1	0.07 mm/tooth
I1	$(24-13)/2 = 5.5$ mm
P1	2.4 mm
For D2	ø18 mm
f2	0.05 mm/tooth
I2	$(18-13)/2 = 2.5$ mm
P2	1.5 mm

```
G00 G90 X5.5 Y0.
S2450 M03
G43 H02 Z10. M08
G01 Z1.7 F200.
Z5.
G03 I-5.5 Z-0.7 F343.
G03 I-5.5 Z-3.1
G03 I-5.5 Z-5.5
G03 I-5.5 Z-7.9
G03 I-5.5 Z-10.3
G03 I-5.5 Z-12.7
G03 I-5.5 Z-15.1
G03 I-5.5 Z-17.5
G03 I-5.5 F200.
G01 X2.5 Y0.
G03 I-2.5 Z-19. F245.
G03 I-2.5 Z-20.5
```

3 Programming a pre-bore hole

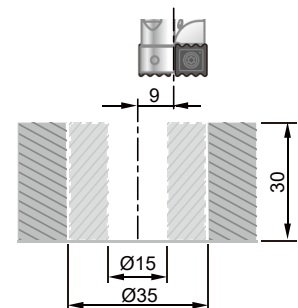



Material	K FCD400
Tool holder	00-99321-016-2030
Insert	01-N9MX070204-NC5072
Prebore	15 mm
Dc	17 mm
Vc	90 m/min.
Pre-bored	ø15 mm
D	ø35 mm
f	0.1 mm/tooth
I	$(35-17)/2 = 9.0$ mm
P	4.0 mm

```
G00 G90 X9. Y0.
S1685 M03
G43 H03 Z30. M08
Z5.
G01 Z2. F200.
G03 I-9. Z-4. F337.
G03 I-9. Z-8.
G03 I-9. Z-12.
G03 I-9. Z-16.
G03 I-9. Z-20.
G03 I-9. Z-24.
G03 I-9. Z-28.
G03 I-9. Z-32.
G03 I-9. F200.
G01 X0. Y0.
G00 G90 Z5. M09
G00 G90 Z30. M05
G28 G91 Z0.
```

Cutting Data

Pitch Suggestion Table			
Spindle Power	< 12 KW	12-20 KW	> 20 KW
Pitch Pick Up	Lower Pitch	Medium Pitch	Higher Pitch

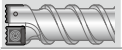
► 00-99321-010-1320 / 00-99323-010-1320 >>

Workpiece material	Vc m/min.		Ø13				Ø16				Ø20				Grade of Insert
	 99321	 99323	fz mm/tooth	Pitch mm			fz mm/tooth	Pitch mm			fz mm/tooth	Pitch mm			
P Carbon steel 0.25%C 0.45% C 0.60%C Low alloy steel High alloy steel	120	200	0.025	0.60	0.80	1.00	0.055	0.90	1.20	1.50	0.08	1.20	1.60	2.00	NC2032
	120	200	0.025	0.60	0.80	1.00	0.055	0.90	1.20	1.50	0.08	1.20	1.60	2.00	NC2032
	100	150	0.025	0.60	0.75	0.90	0.05	0.80	1.10	1.35	0.07	1.00	1.40	1.80	NC5075
	70	120	0.02	0.50	0.65	0.80	0.05	0.70	0.95	1.20	0.06	1.00	1.30	1.60	NC5072
	60	90	0.02	0.50	0.65	0.80	0.05	0.70	0.95	1.20	0.06	1.00	1.30	1.60	NC5072
M Stainless steel	60	90	0.02	0.50	0.65	0.80	0.05	0.70	0.95	1.20	0.06	1.00	1.30	1.60	NC5072
K Cast iron	70	120	0.025	0.60	0.80	1.00	0.055	0.90	1.20	1.50	0.08	1.20	1.60	2.00	NC2032
N Al Cu	345	500	0.025	0.90	1.20	1.50	0.055	1.30	1.80	2.25	0.08	1.80	2.40	3.00	NC2032
	200	400	0.025	0.70	0.95	1.20	0.055	1.00	1.40	1.80	0.08	1.40	1.90	2.40	NC2032
S Ni-alloy Titanium	20	28	0.01	0.50	0.65	0.80	0.015	0.70	0.95	1.20	0.03	0.90	1.30	1.60	NC5075
	40	60	0.01	0.50	0.65	0.80	0.015	0.70	0.95	1.20	0.03	0.90	1.30	1.60	NC5072
H Hardened steel< 50HRC	60	90	0.02	0.50	0.65	0.80	0.05	0.70	0.95	1.20	0.06	1.00	1.30	1.60	NC5075

► 00-99321-012-1525 / 00-99323-012-1525 >>

Workpiece material	Vc m/min.		Ø15				Ø20				Ø25				Grade of Insert
	 99321	 99323	fz mm/tooth	Pitch mm			fz mm/tooth	Pitch mm			fz mm/tooth	Pitch mm			
P Carbon steel 0.25%C 0.45% C 0.60%C Low alloy steel High alloy steel	120	200	0.035	1.20	1.60	2.00	0.065	1.50	2.00	2.50	0.09	1.80	2.40	3.00	NC2032
	120	200	0.035	1.20	1.60	2.00	0.065	1.50	2.00	2.50	0.09	1.80	2.40	3.00	NC2032
	100	150	0.03	1.10	1.50	1.80	0.06	1.30	1.78	2.25	0.08	1.60	2.15	2.70	NC5075
	70	120	0.025	1.00	1.30	1.60	0.05	1.20	1.60	2.00	0.07	1.40	1.90	2.40	NC5072
	60	90	0.025	1.00	1.30	1.60	0.05	1.20	1.60	2.00	0.07	1.40	1.90	2.40	NC5072
M Stainless steel	60	90	0.025	1.00	1.30	1.60	0.05	1.20	1.60	2.00	0.07	1.40	1.90	2.40	NC5072
K Cast iron	70	120	0.035	1.20	1.60	2.00	0.065	1.30	1.90	2.50	0.09	1.80	2.40	3.00	NC2032
N Al Cu	345	500	0.035	1.80	2.00	2.20	0.065	2.20	2.98	3.75	0.09	2.70	3.60	4.30	NC2032
	200	400	0.035	1.40	1.90	2.20	0.065	1.80	2.40	3.00	0.09	2.10	2.85	3.60	NC2032
S Ni-alloy Titanium	20	28	0.0125	1.00	1.30	1.60	0.0225	1.20	1.60	2.00	0.03	1.40	1.90	2.40	NC5075
	40	60	0.0125	1.00	1.30	1.60	0.0225	1.20	1.60	2.00	0.03	1.40	1.90	2.40	NC5072
H Hardened steel< 50HRC	60	90	0.025	1.00	1.30	1.60	0.05	1.20	1.60	2.00	0.07	1.40	1.90	2.40	NC5075

6

NC Helix Drill

Cutting Data

Pitch Suggestion Table			
Spindle Power	< 12 KW	12-20 KW	> 20 KW
Pitch Pick Up	Lower Pitch	Medium Pitch	Higher Pitch

► 00-99321-016-2030 / 00-99323-016-2030 >>

Workpiece material	Vc m/min.		Ø20			Ø25			Ø30			Grade of Insert			
	 99321	 99323	fz mm/tooth	Pitch mm		fz mm/tooth	Pitch mm		fz mm/tooth	Pitch mm					
P Carbon steel 0.25%C	120	200	0.04	1.80	2.40	3.00	0.08	2.10	2.80	3.50	0.105	2.40	3.20	4.00	NC2032
	120	200	0.04	1.80	2.40	3.00	0.08	2.10	2.80	3.50	0.105	2.40	3.20	4.00	NC2032
	100	150	0.035	1.60	2.15	2.70	0.07	1.90	2.55	3.20	0.09	2.10	2.85	3.60	NC5075
	70	120	0.03	1.40	1.90	2.40	0.065	1.60	2.20	2.80	0.08	1.90	2.55	3.20	NC5072
	60	90	0.03	1.40	1.90	2.40	0.065	1.60	2.20	2.80	0.08	1.90	2.55	3.20	NC5072
M Stainless steel	60	90	0.03	1.40	1.90	2.40	0.065	1.60	2.20	2.80	0.08	1.90	2.55	3.20	NC5072
K Cast iron	70	120	0.04	1.80	2.40	3.00	0.08	2.10	2.80	3.50	0.105	2.40	3.20	4.00	NC2032
N Al	345	500	0.04	2.70	3.00	3.40	0.08	3.10	4.05	5.00	0.105	3.60	4.80	5.60	NC2032
	Cu	200	400	0.04	2.10	2.85	3.40	0.08	2.50	3.35	4.20	0.105	2.80	3.80	4.80
S Ni- alloy	20	28	0.015	1.40	1.90	2.40	0.03	1.60	2.20	2.80	0.04	1.90	2.55	3.20	NC5075
	Titanium	40	60	0.015	1.40	1.90	2.40	0.03	1.60	2.20	2.80	0.04	1.90	2.55	3.20
H Hardened steel< 50HRC	60	90	0.03	1.40	1.90	2.40	0.065	1.60	2.20	2.80	0.08	1.90	2.55	3.20	NC5075

► 00-99321-020-2540 / 00-99323-020-2540 >>

Workpiece material	Vc m/min.		Ø25			Ø32			Ø40			Grade of Insert			
	 99321	 99323	fz mm/tooth	Pitch mm		fz mm/tooth	Pitch mm		fz mm/tooth	Pitch mm					
P Carbon steel 0.25%C	120	200	0.05	1.80	2.40	3.00	0.095	2.40	3.20	4.00	0.12	3.00	4.00	5.00	NC2032
	120	200	0.05	1.80	2.40	3.00	0.095	2.40	3.20	4.00	0.12	3.00	4.00	5.00	NC2032
	100	150	0.04	1.60	2.15	2.70	0.08	2.20	2.90	3.60	0.11	2.70	3.60	4.50	NC5075
	70	120	0.035	1.40	1.90	2.40	0.07	1.90	2.55	3.20	0.095	2.40	3.20	4.00	NC5072
	60	90	0.035	1.40	1.90	2.40	0.07	1.90	2.55	3.20	0.095	2.40	3.20	4.00	NC5072
M Stainless steel	80	90	0.035	1.40	1.90	2.40	0.07	1.90	2.55	3.20	0.095	2.40	3.20	4.00	NC5072
K Cast iron	70	120	0.05	1.80	2.40	3.00	0.095	2.40	3.20	4.00	0.12	3.00	4.00	5.00	NC2032
N Al	345	500	0.05	2.70	3.00	3.40	0.095	3.60	4.80	6.00	0.12	4.50	6.00	7.50	NC2032
	Cu	200	400	0.05	2.10	2.85	3.40	0.095	2.90	3.85	4.80	0.12	3.60	4.80	6.00
S Ni- alloy	40	50	0.02	1.40	1.90	2.40	0.035	1.90	2.55	3.20	0.045	2.40	3.20	4.00	NC5075
	Titanium	80	90	0.02	1.40	1.90	2.40	0.035	1.90	2.55	3.20	0.045	2.40	3.20	4.00
H Hardened steel< 50HRC	80	90	0.035	1.40	1.90	2.40	0.07	1.90	2.55	3.20	0.095	2.40	3.20	4.00	NC5075

Cutting Data

Pitch Suggestion Table			
Spindle Power	< 12 KW	12-20 KW	> 20 KW
Pitch Pick Up	Lower Pitch	Medium Pitch	Higher Pitch

▶ 00-99321-025-3050 / 00-99323-025-3050 >>

Workpiece material	Vc m/min.		Ø30			Ø40			Ø50			Grade of Insert			
	 99321	 99323	fz mm/tooth	Pitch mm		fz mm/tooth	Pitch mm		fz mm/tooth	Pitch mm					
P Carbon steel 0.25%C 0.45% C 0.60%C Low alloy steel High alloy steel	120	200	0.055	2.40	3.00	3.40	0.12	3.00	4.00	5.00	0.135	3.60	4.80	6.00	NC2032
	120	200	0.055	2.40	3.00	3.40	0.12	3.00	4.00	5.00	0.135	3.60	4.80	6.00	NC2032
	100	150	0.05	2.20	2.90	3.40	0.10	2.70	3.60	4.50	0.12	3.20	4.30	5.40	NC5075
	70	120	0.04	1.90	2.55	3.20	0.09	2.40	3.20	4.00	0.11	2.90	3.85	4.80	NC5072
	60	90	0.04	1.90	2.55	3.20	0.09	2.40	3.20	4.00	0.11	2.90	3.85	4.80	NC5072
M Stainless steel	60	90	0.04	1.90	2.55	3.20	0.09	2.40	3.20	4.00	0.11	2.90	3.85	4.80	NC5072
K Cast iron	70	120	0.055	2.40	3.00	3.40	0.115	3.00	4.00	5.00	0.135	3.60	4.80	6.00	NC2032
N Al Cu	345	500	0.055	2.50	3.00	3.40	0.115	4.50	6.00	7.50	0.135	5.40	7.20	9.00	NC2032
	200	400	0.055	2.50	3.00	3.40	0.115	3.60	4.80	6.00	0.135	4.30	5.75	7.20	NC2032
S Ni-alloy Titanium	20	28	0.02	1.90	2.55	3.20	0.045	2.40	3.20	4.00	0.055	2.90	3.85	4.80	NC5075
	40	60	0.02	1.90	2.55	3.20	0.045	2.40	3.20	4.00	0.055	2.90	3.85	4.80	NC5072
H Hardened steel< 50HRC	60	90	0.04	1.90	2.55	3.20	0.09	2.40	3.20	4.00	0.11	2.90	3.85	4.80	NC5075

▶ 00-99321-025-4265 >>

Workpiece material	Vc m/min.	Ø42			Ø55			Ø65			Grade of Insert			
	 99321	fz mm/tooth	Pitch mm		fz mm/tooth	Pitch mm		fz mm/tooth	Pitch mm					
P Carbon steel 0.25%C 0.45% C 0.60%C Low alloy steel High alloy steel	200	0.08	3.00	3.60	4.40	0.12	3.30	4.40	5.50	0.135	3.60	4.80	6.00	NC2032
	150	0.08	3.00	3.60	4.40	0.12	3.30	4.40	5.50	0.135	3.60	4.80	6.00	NC2032
	130	0.075	2.70	3.60	4.40	0.11	3.00	4.00	5.00	0.12	3.20	4.30	5.40	NC5075
	120	0.065	2.40	3.20	4.00	0.095	2.60	3.50	4.40	0.11	2.90	3.85	4.80	NC5072
	90	0.065	2.40	3.20	4.00	0.095	2.60	3.50	4.40	0.11	2.90	3.85	4.80	NC5072
M Stainless steel	90	0.065	2.40	3.20	4.00	0.095	2.60	3.50	4.40	0.11	2.90	3.85	4.80	NC5072
K Cast iron	120	0.08	3.00	3.60	4.40	0.12	3.30	4.40	5.50	0.135	3.60	4.80	6.00	NC2032
N Al Cu	500	0.08	4.00	4.20	4.40	0.12	4.90	6.55	8.20	0.135	5.40	7.20	9.00	NC2032
	200	0.08	3.60	4.00	4.40	0.12	4.00	5.30	6.60	0.135	4.30	5.75	7.20	NC2032
S Ni-alloy Titanium	28	0.03	2.40	3.20	4.00	0.045	2.60	3.50	4.40	0.055	2.90	3.85	4.80	NC5075
	90	0.03	2.40	3.20	4.00	0.045	2.60	3.50	4.40	0.055	2.90	3.85	4.80	NC5072
H Hardened steel< 50HRC	90	0.065	2.40	3.20	4.00	0.095	2.60	3.50	4.40	0.11	2.90	3.85	4.80	NC5075

6

NC Helix Drill

Application Example

► Special insert geometry is able to cut different materials >>

- Serrated cutting edge makes the chips short and small, and easier to evacuate.
- Recommended for almost all material types, good for drilling material that generates long, soft chips.





Material: SAE8620		Load 25% P
Vc	= 120 m/min.	
S	= 2250 r.p.m.	
fz	= 0.08 mm/tooth	
F	= 360 mm/min	
P	= 5.6 mm	
T	= 40 sec.	

Material: SUS304 (Stainless steel 304)		Load 25% M
Vc	= 80 m/min.	
S	= 1500 r.p.m.	
fz	= 0.04 mm/tooth	
F	= 120 mm/min	
P	= 5.6 mm	
T	= 118 sec.	

Material: C1100		Load 25% N
Vc	= 200 m/min.	
S	= 3750 r.p.m.	
fz	= 0.08 mm/tooth	
F	= 600 mm/min	
P	= 5.6 mm	
T	= 23 sec.	

Material: AL6061T6		Load 20% N
Vc	= 345 m/min.	
S	= 6500 r.p.m.	
fz	= 0.10 mm/tooth	
F	= 1300 mm/min	
P	= 5.6 mm	
T	= 11 sec.	

Material: TiAl6V4		Load 24% S
Vc	= 80 m/min.	
S	= 1500 r.p.m.	
fz	= 0.04 mm/tooth	
F	= 120 mm/min	
P	= 5.6 mm	
T	= 118 sec.	

Material: Inconel 718 (Drill with internal coolant)		Load 24% S
Vc	= 40 m/min.	
S	= 750 r.p.m.	
fz	= 0.15 mm/tooth	
F	= 225 mm/min	
P	= 2.0 mm	
T	= 177 sec.	

► Suggested insert grades for best result >>

Diameter (mm)	25		
Depth (mm)	50		
Tool (Dc=17mm)	00-99321-016-2030 (external coolant)		
Material	P Carbon Steel	M Stainless Steel	H Tool Steel
	DIN C45E	X5CrNi18-10	X40CrMoV5 1
	SAE 1045	304	H13
	JIS S45C	SUS304	SKD61 (HRC50°)
Insert Grade	NC5072 (P40, TiAlN)	NC5072 (P40, TiAlN)	NC2032 (K20F, TiAlN)
No. of Edges	2	2	2
Vc = (m/min.)	120	60	80
S = r.p.m.	2250	1120	1500
fz = (mm/tooth)	0.1	0.065	0.05
F = (mm/min.)	450	146	150
Pitch = (mm)	5.6	3	3
Machine Load = % (BT40, 22.5KW)	35%	20%	20%
Tool Life (hole)	150	108	18
Chip Removal Volume (cm ³ /min.)	52.66	8.55	8.77

► To produce step hole Ø53.5 & Ø45 by one tool >>



Application

- Hydraulic port for plug-in valve cylinders, counterbore for bolt, and more!

Material	S50C (JIS). High carbon steel									
Tool	99323-LS32-HD40 (Non-standard size)									
Insert	N9MX12T308-NC2032									
Machine	BT40, 22.5 KW									
Coolant	Internal									
Hole	Dc mm	D mm	L mm	Vc m/min.	S r.p.m.	fz mm/tooth	F mm/min.	I mm	P mm	T sec.
A	Ø40	Ø53.5	10	300	2400	0.08	380	6.75	5.0	13.3
B		Ø45.0	32	300	2400	0.08	380	2.5	2.0	39.48

► Just one “NC Helix Drill” can machine different diameters and hole depths.

► Just one tool to drill different diameters and hole depth, possible up to 6xDc >>

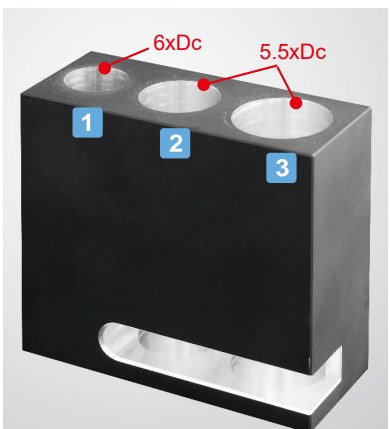

Material	AL6061T6										
Tool	00-99323-016-2030										
Insert	N9MX070204-NC5072										
Machine	HAAS VM-3, BT40, 22.5KW										
Coolant	Internal coolant										
Fig.	Dc mm	D mm	I mm	L mm	Vc m/min.	S r.p.m.	fz mm/tooth	fcut mm/tooth	F mm/min.	P mm	α deg
1	Ø17	20	1.5	100	500	9360	0.04	0.058	1090	3	17.67
2		25	4	95	500	9360	0.08	0.103	1930	4.5	10.16
3		30	6.5	95	500	9360	0.105	0.131	2450	5.6	7.81

► One tool performs multiple patterns >>



Material	AL6061T6						
Tool	00-99323-016-2030 M08-HD17-2030						
Insert	N9MX070204-NC5072						
Machine	HAAS VM-3, BT40, 22.5KW						
Coolant	Internal						
Fig.	Dc mm	Vc m/min.	S r.p.m.	fz mm/tooth	F mm/min.	P mm	T sec.
1	Ø17	200	3800	0.075	570	4	67
2		200	3800	0.075	570	4	95
3		200	3800	0.075	570	4	80

► **Widening a deep hole (6xD) in stainless steel by NC Helix Drill.**
Predrilled 15mm enlarge to 29mm. >>

Ø15mm hole Ø29mm hole



Material		Stainless steel					
Tool		00-99323-016-2030 with 0-398016-150M08 Extension Bar					
Insert		N9MX070204-NC5072					
Machine		VMC m/c.					
Coolant		Internal coolant					
Dc mm	D mm	L mm	S r.p.m.	fz mm/tooth	F mm/min.	P mm	
Ø17	Ø29	105	1685	0.05	168	1.5	

► **Low spindle power is not a problem!**
BT30 machine, Ø30 hole diameter, 3.3xDc drill depth >>

The main purpose of this example is to improve machining efficiency.

Maximum drilling capacity of the 5.5 kw spindle is Ø16 mm



Material		S50C (JIS), High carbon steel								
Tool		00-99321-020-2540 / BC20-HD22-2540								
Insert		N9MX100306-NC2032								
Machine		BT30, 5.5 KW								
Coolant		External coolant								
Dc mm	D mm	L mm	Vc m/min.	S r.p.m.	fz mm/tooth	fcut mm/tooth	F mm/min.	I mm	P mm	T sec.
Ø22	Ø30	60	200	* 2893	0.12	0.1	600	4	2.8	62

* 3000 r.p.m. is used.

► **NC Helix Drill reduces the spindle load and increases spindle life. >>**

Maximum drilling capacity of the 18 kw spindle is Ø50 mm

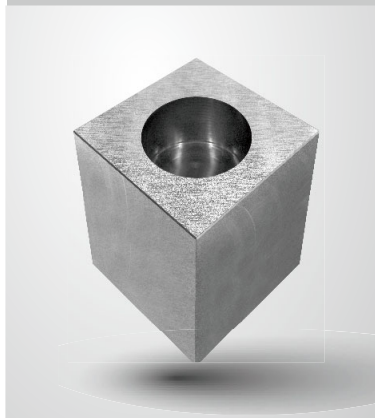

Material		SS400 Low carbon steel								
Tool		00-99323-025-3050								
Insert		N9MX12T308-NC5072								
Machine		Toshiba MPE-2140, CAT-50, 25HP / 18KW								
Coolant		Internal coolant								
Dc mm	D mm	L mm	Vc m/min.	S r.p.m.	fz mm/tooth	fcut mm/tooth	F mm/min.	I mm	P mm	T sec.
Ø27	Ø50	80	119	1400	0.15	0.165	420	11.5	3	275

15% Spindle load only!